

FRIMEDA LIFTING ANCHOR SYSTEM

Application and misuse

1. Engaging

Insert the ring clutch in the recess in the concrete and close the locking bolt or the slide manually, pushing it to the limit position. Then start the lifting operation.

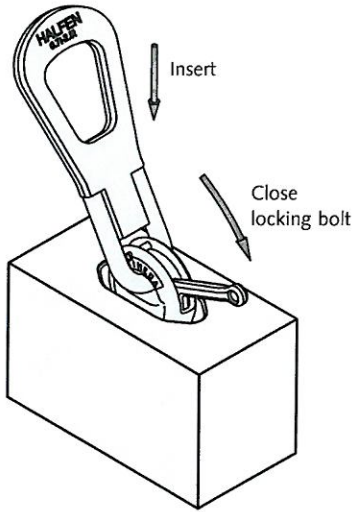

2. Lifting

The ring clutch can be subjected to loads in any direction (do not exceed the load limits of the anchors!). Angled pull of up to 60° due to the use of a spreader is permitted.

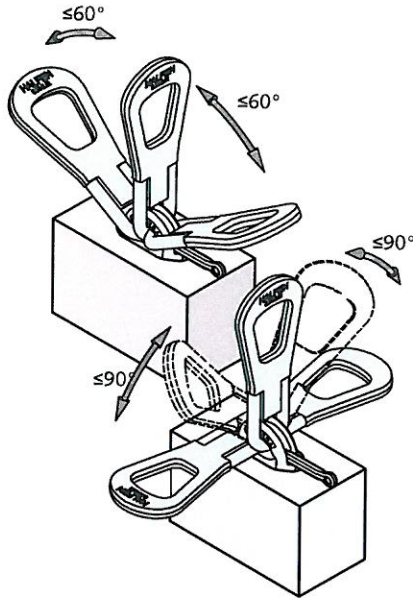

3. Releasing

Manual ring clutch: push back the bolt by hand. Now the ring clutch is free.

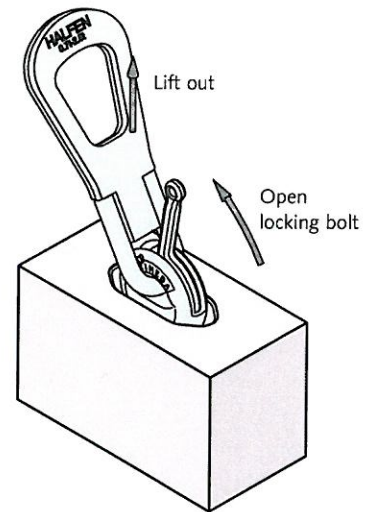

Misuse of the FRIMEDA ring clutch

If the shackle is beneath the clutch head when subjected to the load, it may lock in the position illustrated. The round shackle will become bent then when the load is raised.

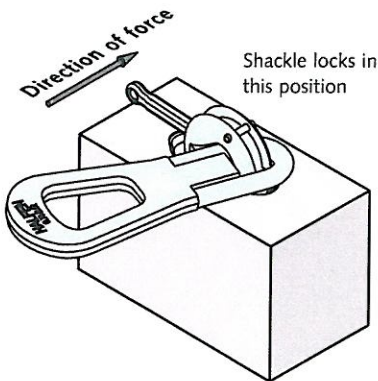

If the shackle is pulled towards the top surface of the slab when subjected to the load, it may become bent on the edge of the slab.

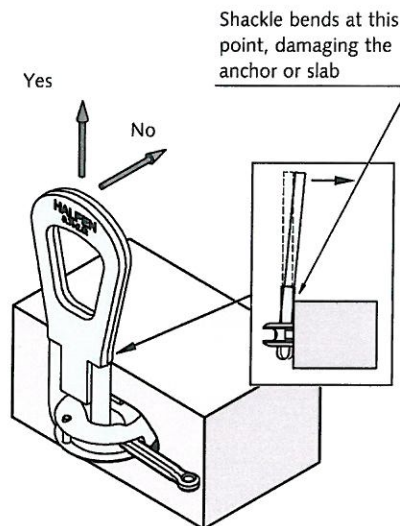

In the upper position, the shackle may lock within the clutch housing. A narrow lifting cable angle will cause the shackle to become bent. The problem can be overcome by turning the shackle through approx. 45°.

